



www.perma-cool.com

Installation Instructions

This guide covers the following Item Number:

24750

*Congratulations, you have made a wise decision.
Thank you for purchasing our product.*

Universal Fan Clutch Replacer

IMPORTANT! READ ALL INSTRUCTIONS BEFORE BEGINNING INSTALLATION.

Remove the old fan and clutch, together as a unit. Remove the fan from the clutch. Your new universal fan clutch replacer has two different fan blade pilot holes; 2 3/8" (60mm) and 2 5/8" (67mm) diameter. Verify which matches the fan clutch fan.

Mount the fan clutch replacer to the fan clutch fan. Measure the water pump shaft. If the shaft is 5/8" [.625] (16mm) install the 5/8" to 3/4" (16mm to 19mm) reducer bushing that has been supplied. Be sure that the fan clutch replacer seats squarely on the water pump flange. Determine whether the coarse thread or fine thread bolts are needed. Be sure to use the correct ones. Tighten all bolts to 15-24 ft. lbs. (21-32Nm). Be careful not to strip the threads. Verify all fan clearances.

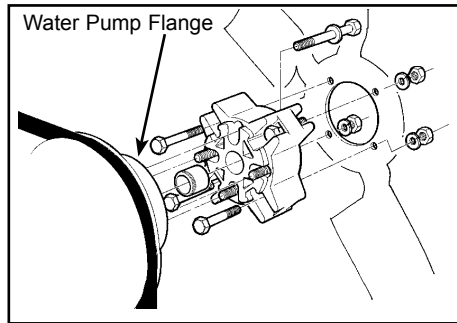

CAUTION: NEVER TURN THE ENGINE WITH THE FAN BLADE.

THIS PRODUCT IS NOT RECOMMENDED FOR HIGH RPM ENGINES!!!

For additional accessories or replacement parts visit www.perma-cool.com



www.perma-cool.com

Installation Instructions

This guide covers the following Item Number:

24750

*Congratulations, you have made a wise decision.
Thank you for purchasing our product.*

Universal Fan Clutch Replacer

IMPORTANT! READ ALL INSTRUCTIONS BEFORE BEGINNING INSTALLATION.

Remove the old fan and clutch, together as a unit. Remove the fan from the clutch. Your new universal fan clutch replacer has two different fan blade pilot holes; 2 3/8" (60mm) and 2 5/8" (67mm) diameter. Verify which matches the fan clutch fan.

Mount the fan clutch replacer to the fan clutch fan. Measure the water pump shaft. If the shaft is 5/8" [.625] (16mm) install the 5/8" to 3/4" (16mm to 19mm) reducer bushing that has been supplied. Be sure that the fan clutch replacer seats squarely on the water pump flange. Determine whether the coarse thread or fine thread bolts are needed. Be sure to use the correct ones. Tighten all bolts to 15-24 ft. lbs. (21-32Nm). Be careful not to strip the threads. Verify all fan clearances.

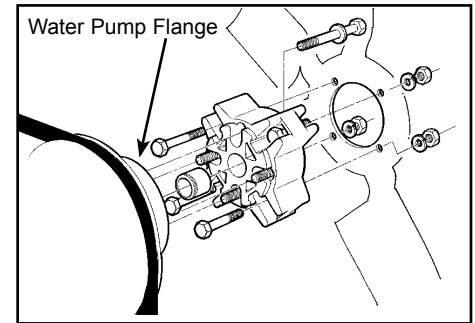

CAUTION: NEVER TURN THE ENGINE WITH THE FAN BLADE.

THIS PRODUCT IS NOT RECOMMENDED FOR HIGH RPM ENGINES!!!

For additional accessories or replacement parts visit www.perma-cool.com