



www.perma-cool.com

Installation Instructions

This guide covers the following Item Numbers:

25100 and 25200

Congratulations, you have made a wise decision. Thank you for purchasing our product.

Heavy Duty Fan Clutch

IMPORTANT! READ ALL INSTRUCTIONS BEFORE BEGINNING INSTALLATION.

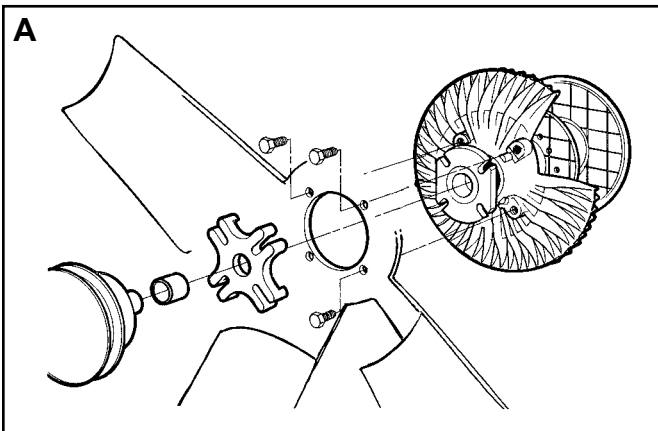

Loosen and remove the fan belt(s). Remove the fan clutch, together with the fan blade attached, from the water pump. **SAVE** all bolts, nuts, washers, etc. for use during re-assembly. Loosen and remove fan shroud or other components, if necessary.

Remove the fan from the fan clutch. Check fan for bent or cracked blades, loose or missing rivets, etc. **DO NOT ATTEMPT TO STRAIGHTEN BENT FAN BLADES!** If fan is damaged, it should be replaced.

Install the fan on the clutch housing by slipping fan over mount shaft using the bolts provided (see illustration A). Fan blades should cup towards the engine. Torque bolts to 10 - 15 ft. lbs., (20.3 - 27.1 Nm).

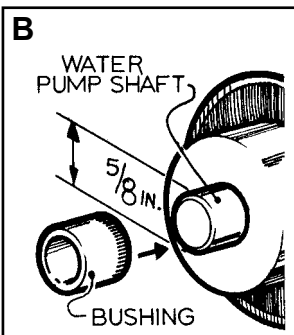

Measure the diameter of the water pump shaft. If the shaft is 5/8" (16mm) in diameter, the reducer bushing that has been provided must be utilized. If the diameter is 3/4" (19mm), the bushing is not required (see illustration B).

A spacer is provided to help maintain the proper distance between the fan clutch assembly and radiator. If needed, install the spacer on the water pump shaft, between the water pump pulley and the fan clutch assembly (see illustration A). Slide the fan clutch assembly into position and rotate the fan **VERY SLOWLY** by hand to verify the minimum blade edge clearance. **NOTE:** It is necessary to maintain 1" (25mm) **MINIMUM CLEARANCE** in all directions of the fan blades (see illustration C).

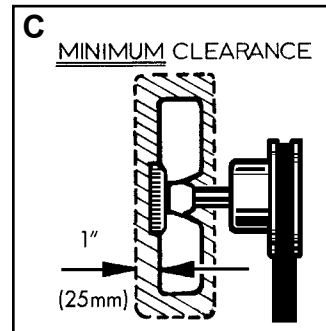

Reattach the fan clutch assembly to the water pump, using all the hardware saved from the disassembly above. Be sure that the pilot hole in the fan clutch assembly is seated squarely on the water pump shaft before tightening the bolts. Torque bolts to 15 -

20 ft. lbs. (20.3 - 27.1 Nm) **DO NOT OVERTIGHTEN THE BOLTS.**

Reinstall the fan belt(s). Adjust as required. Reinstall the fan shroud and other parts that may have been removed to ease installation. Check all bolts for tightness. Rotate the fan by hand, slipping the clutch, to verify all clearances again. Start engine and check for wobble or vibration.

U.S. Patent Number 4,899,860
ROC Patent Number UM 44,733

For additional accessories or replacement parts visit www.perma-cool.com